

SG-PTZ2090NO-L1K5

- 2Mp 90x Long Range Zoom Starlight Laser Network Vehicle PTZ Camera



1. Features

- > Sony Exmor Starlight CMOS Sensor
- > Powerful 90x(6~540mm) optical zoom
- > Max. 25/30fps @ 2MP(1920x1080) Resolution
- > Support various IVS functions
- > Up to 1500m Laser IR Distance
- > Military Connector
- > IP66

2. Specification

Model		SG-PTZ2090NO-L1K5			
Sensor	Image Sensor	1/1.8" Sony Starvis progressive scan CMOS			
	Effective Pixels	Approx. 8.42 Megapixel			
Lens	Focal Length	6mm~540mm, 90x Optical Zoom			
	Aperture	F1.4~F4.8			
	Field of View	H: 65.2°~0.8°, V: 39.5°~0.4°, D: 72.5°~0.9°			
	Close Focus Distance	1m~1.5m (Wide~Tele)			
	Zoom Speed	Approx. 9s (Optical Wide~Tele)			
	DORI Distance (Human)	Detect	Observe	Recognize	Identify
	4,889m	1,940m	977m	488m	
Video	Compression	H.265/H.264/H.264H/MJPEG			
	Streaming Capability	3 streams			

	Resolution	50Hz: 25fps@2MP(1920×1080), 25fps@1MP(1280×720) 60Hz: 30fps@2MP(1920×1080), 30fps@1MP(1280×720)
	Video Bit Rate	32kbps~16Mbps
	Audio	AAC / MP2L2
Network	Storage	TF card (256 GB), FTP, NAS
	Network Protocol	Onvif, HTTP, HTTPS, IPv4, IPv6, RTSP, DDNS, RTP, TCP, UDP
	Multicast	Support
General Events		Motion, Tamper, SD Card, Network
IVS		Tripwire, Cross Fence Detection, Intrusion, Abandoned Object, Fast-Moving, Parking Detection, Crowd Gathering Estimation, Missing Object, Loitering Detection.
S/N Ratio		≥55dB (AGC Off, Weight ON)
Minimum Illumination		Color: 0.01Lux/F1.4; B/W: 0.001Lux/F1.4
Noise Reduction		2D/3D
Exposure Mode		Auto, Aperture Priority, Shutter Priority, Gain Priority, Manual
Exposure Compensation		Support
Shutter Speed		1/1~1/30000s
BLC		Support
HLC		Support
WDR		Support
White Balance		Auto, Manual, Indoor, Outdoor, ATW, Sodium lamp, Street lamp, Natural, One Push
Day/Night		Electrical, ICR(Auto/Manual)
Focus Mode		Auto, Manual, Semi Auto, Fast Auto, Fast Semi Auto, One Push AF
Electronic Defog		Support
Optical Defog		Support, 750nm~1100nm channel is Optical Defog
Heat Haze Reduction		Support
Flip		Support
EIS		Support
Digital Zoom		16x
IR Distance		Up to 1500m
IR On/OFF Control		Auto/Manual
IR LEDs		Laser Module
Wiper		N/A
PTZ	Material	Integrative structure design, Aluminum-Alloy shell
	Driving Mode	Turbine Worm Drive
	Power-Off Protection	Support
	Pan/Tilt Range	Pan: 360°, Endless; Tilt: -84°~84°
	Pan/Tilt Speed	Adjustable, pan: 0°~60°/s; Tilt: 0°~40°/s;
	Tour	4

	Presets	128
	Protocol	Pelco-P/D
	Military Connector	Support
Ethernet	RJ-45 (10Base-T/100Base-TX)	
RS485	1	
Audio I/O	1/1	
Alarm I/O	1/1	
Cable	5m by default (with 2m Circle Protection part)	
Power Supply	DC24~36V±15% / AC24V	
Power Consumption	56W	
Operating Conditions	-30°C~+60°C/20% to 80%RH	
Protection Level	IP66; TVS 4000V Lightning Protection, surge prevention	
Casing	Metal	
Color	White by default (Black Optional)	
Dimensions(L*W*H)	Approx. 260mm*387mm*265mm	
Net Weight	8.8kg	
Gross Weight	16.7kg	

3. Dimension

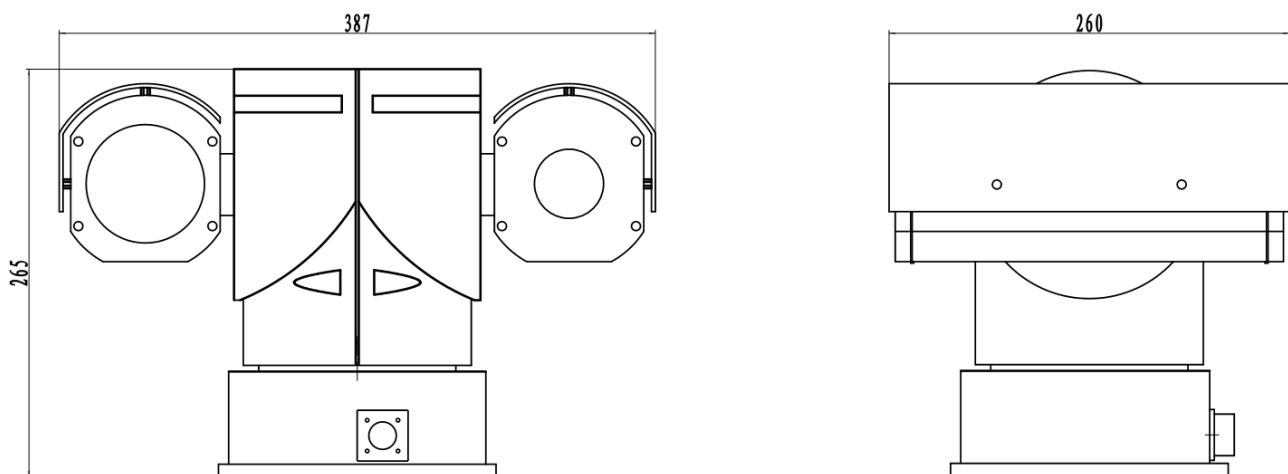

Hangzhou Savgood Technology Co., Ltd.

Rm. 701, Xincheng Fazhan Building #1, No. 406 Xintiandi Street,
 Xiacheng District, Hangzhou City, 310004, China
 Tel: +86 - (571) 8803 8121
 Email: sales@savgood.com
<http://www.savgood.com>
<http://www.savgoodtech.com>

*Design and specifications are subject to change without prior notification.
 © 2013 Savgood Technology Co., Ltd.